

5mm Round Package Silicon Phototransistor

OP T538

Features

- Matched to Infrared Emitter 940nm
- High photo sensitivity
- High speed and high sensitive silicon NPN material
- Lens in water clear

Applications

- Detector for industrial electronic circuitry
- Encoder
- Interrupter
- Infrared detector

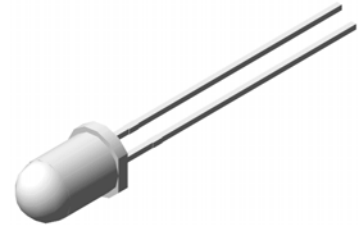

Absolute Maximum Rating at Ta =25°C, unless otherwise specified

Parameter	Symbol	Value	Unit
Emitter-Collector Voltage	V_{ECO}	5	V
Collector-Emitter Voltage	V_{CEO}	30	V
Collector Current	I_C	20	mA
Power Dissipation	P_c	80	mW
Operating Temperature Range	T_{opr}	-30 to + 85	°C
Storage Temperature	T_{stg}	-40 to + 85	°C
Soldering Temperature	T_{sol}	260	°C

Note: Please take note the Absolute Maximum Rating values. Any operation beyond the specified ratings in this table will result degradation of product life-span and may cause to fail.

Package Dimension:

unit: mm

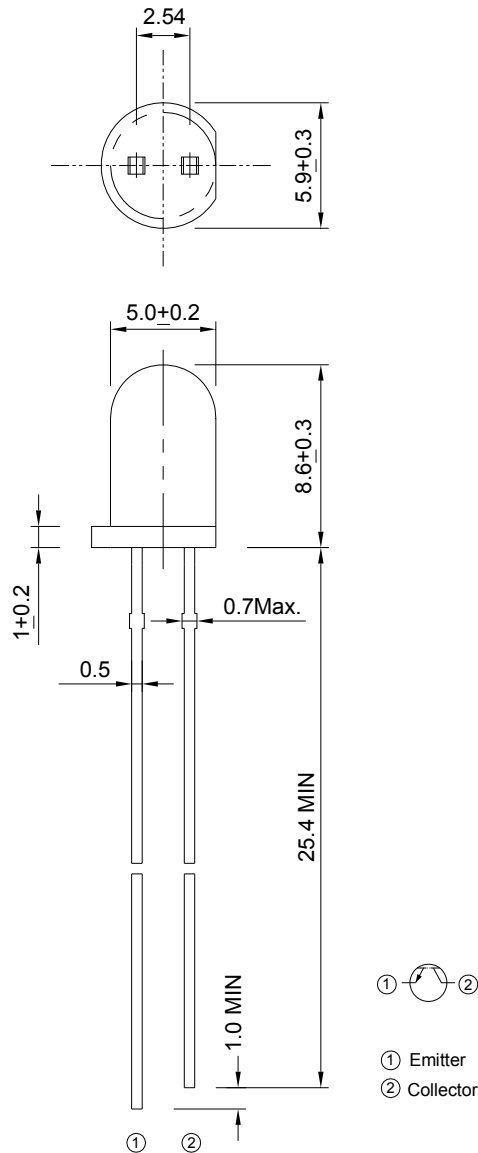

Notes:

1. All dimensions are millimeters.
2. Tolerance is ± 0.2 mm unless otherwise specified.
3. Specifications are subject to change without notice.

Optical Characteristics at Ta=25°C, unless otherwise specified

Parameter	Test condition	Symbol	Min	Typ.	Max	Unit
Emitter-Collector Breakdown Voltage	$I_E = 100\mu A$ $E_e = 0mW/cm^2$	BV_{ECO}	5	---	---	V
Collector- Emitter Breakdown Voltage	$I_C = 1mA$ $E_e = 0mW/cm^2$	BV_{CEO}	30	---	---	V
Collector-Emitter Saturation Voltage	$I_C = 80\mu A$ $E_e = 1mW/cm^2$	$V_{CE(SAT)}$	---	---	0.4	V
Collector Dark Current	$E_e = 0mW/cm^2$ $V_{CE} = 10V$	I_{CEO}	---	---	100	nA
On State Collector Current	$E_e = 1mW/cm^2$ $V_{CE} = 5V$	$I_{C(ON)}$	1.77	3.0		mA
Range of Spectral Bandwidth	---	$\lambda_{0.5}$	400	---	1200	nm
Wavelength of Peak Sensitivity	---	λ_p	---	860	---	nm
Rise Time	$V_{ce}=5V, I_c=0.5mA,$ $R_L=100\Omega$	T_r	---	15	---	μS
Fall Time		T_f		15	---	

Ranks

Parameter	Symbol	Min.	Max.	Unit	Test Condition
1	$I_{C(ON)}$	1.77	3.60	mA	$E_e = 1mW/cm^2$ $V_{CE} = 5V$
2		2.70	5.10		

Typical Electro-optical Characteristics Curves

