

## Super Flux LED with 50 Degree View Angle

### VT 6748.51

#### Description

The series of LEDs is known as 'Super Flux' LED, able to withstand high drive current application. With special design Lead-Frame, the heat dissipation capability is increased. During high operating forward current, the luminous intensity is increase tremendously. As such, the overall cost is reduced with less number of LEDs being used. These LEDs can be used as Traffic Single Light, Signal Board or in Full Color applications.

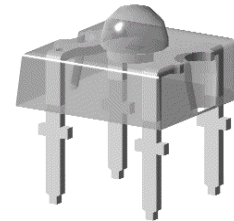

#### Features

- High luminous flux output
- Supreme heat dissipation
- Package in tubes for automatic insertion
- Luminous and color categorized for each tube

RoHS



#### Electronic Optical Characteristics (at 70mA):

Part Number	Emitted Color	$\lambda$ (nm)		Lens Color	Flux (mlm)		View Angle (2 $\theta$ 1/2)	VF(V)	
		$\lambda$ d	$\lambda$ p		Min.	Typ.		Typ.	Max.
VT 6748.51	Red 	624	632	Clear	3550	4500	50	2.6	3.1

#### Absolute Maximum Ratings at Ta=25°C

Emitted Color	P <sub>D</sub> (mW)	ESD(V)	I <sub>F</sub> (mA)	T <sub>sol</sub> (°C)	I <sub>R</sub> ( $\mu$ A)@V <sub>R</sub> =5V	T <sub>opr</sub> (°C)	T <sub>stg</sub> (°C)
Red (624nm)	220	2000	70	260 $\pm$ 5	10	-40~+85	-40+100

Note: Please take note the Absolute Maximum Rating values. Any operation beyond the specified ratings in this table will result degradation of LED life-span and may cause LED to fail.

**Package Dimension:**

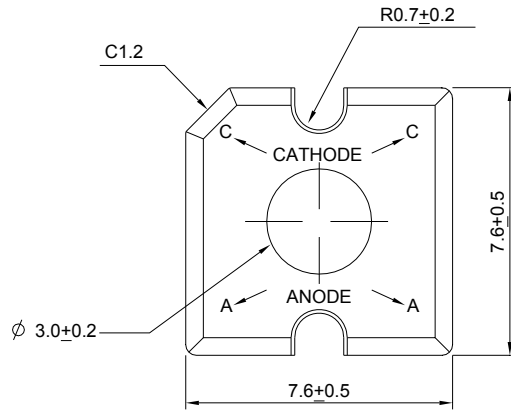

unit:mm

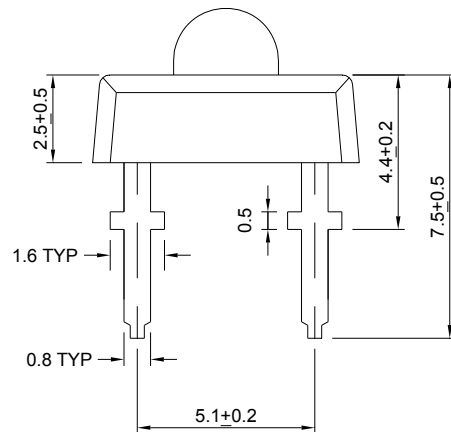
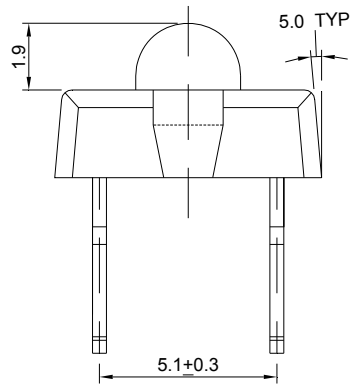
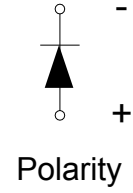

**Notes:**

1. All dimensions are millimeters.
2. Dimensional tolerance is  $\pm 0.2$ mm unless otherwise specified.
3. Epoxy meniscus under flange is 1.5 mm max.
4. Specifications are subject to change without notice.

## Typical Electro-optical Characteristics Curves

Relative Intensity vs. Wavelength

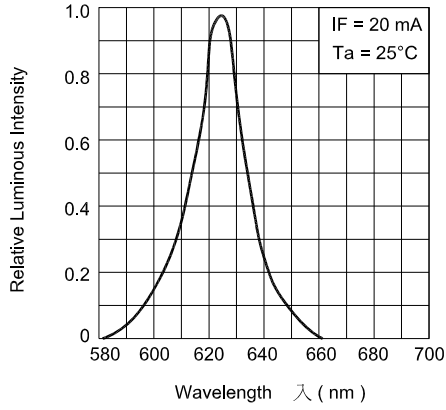

Forward Current vs. Forward Voltage

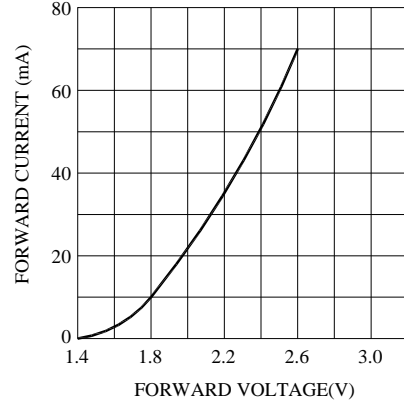

Relative Intensity vs. Forward Current

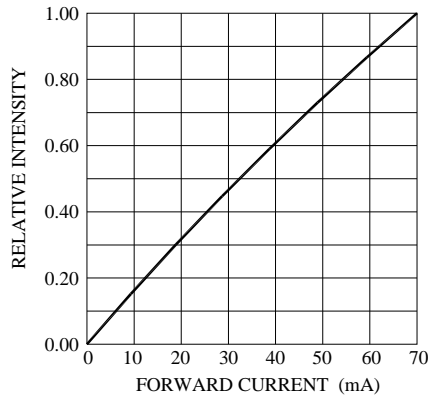

Forward Current vs. Ambient Temp.

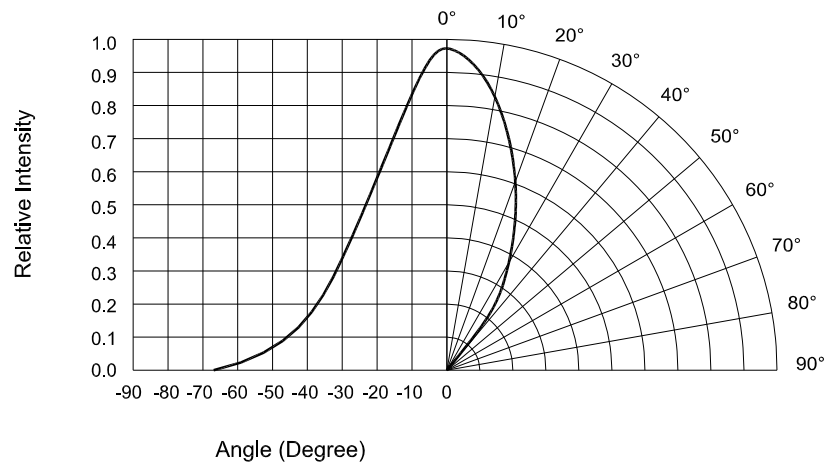
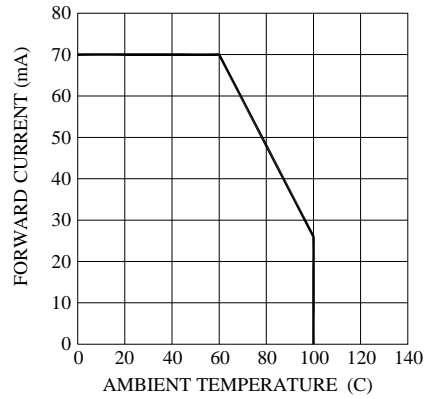

**Specification for Bin Range:****Luminous intensity Rank @ 70 mA**

<b>Bin Code</b>	<b>51</b>	<b>52</b>	<b>53</b>	<b>--</b>
<b>Iv (mlm)</b>	3550-4500	4500-5600	5600-7100	--

**Wavelength Rank @ 70 mA**

<b>Bin Code</b>	<b>R1</b>	<b>R2</b>	<b>--</b>	<b>--</b>
<b><math>\lambda d</math> (nm)</b>	620-624	624-628	--	--

**Forward Voltage Ranks @ 70mA**

<b>Bin Code</b>	<b>1</b>	<b>2</b>	<b>3</b>	<b>4</b>	<b>5</b>
<b>V<sub>F</sub> (V)</b>	2.1-2.3	2.3-2.5	2.5-2.7	2.7-2.9	2.9-3.1