

Subminiature 940nm Infrared LED

UL J628

Description

The UL J628 is used high efficiency 940nm GaAlAs materials, molded into 'Yoke' Lead SMT package with clear lens. Comparing conventional GaAs/GaAs technology under similar wavelength, GaAlAs offers much higher radiant power. The viewing angle being offered is 25 degree. viewing angles being offered is 60 degree. The most suitable application is Infrared Remote Control unit.

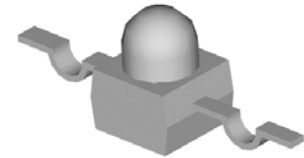

Applications

- Opto-Electronic switch
- Infrared remote control unit
- Free air transmission system
- Infrared applied system



pb-free

Electronic Optical Characteristics (at 20mA):

Part Number	λ (nm)		Lens Color	mW/sr		View Angle ($2\theta_{1/2}$)	VF(V)	
	λ_p	$\Delta\lambda$		Min.	Typ.		Typ.	Max.
UL J628	940	45	Water Clear	3.0	5.0	25	1.2	1.5

* Radiant Intensity Typ. 25 mW/sr @ $I_F=100mA$, $t_p=100\mu$ sec, $t_p/T=0.01$, $V_F @ 1.90$ Max.

Absolute Maximum Ratings (at $T_a=25^\circ C$)

Parameter	Symbol	Rating	Unit	Condition
Continuous Forward Current	I_F	65	mA	
Peak Forward Current		1.0	A	Pulse Width=100us Duty Cycle = 1%
Soldering Temperature	T_{sol}	260	$^\circ C$	4mm from lens body 1 less than 5 seconds
Storage Temperature	T_{stg}	-40 - +85	$^\circ C$	
Operating Temperature	T_{opr}	-25 - +85	$^\circ C$	
Power Dissipation	PD	130	mW	$25^\circ C$ Free Air Temperature

Note: Please take note the Absolute Maximum Rating values. Any operation beyond the specified ratings in this table will result degradation of LED life- span and may cause LED to fail.

Package Dimension:

unit : mm

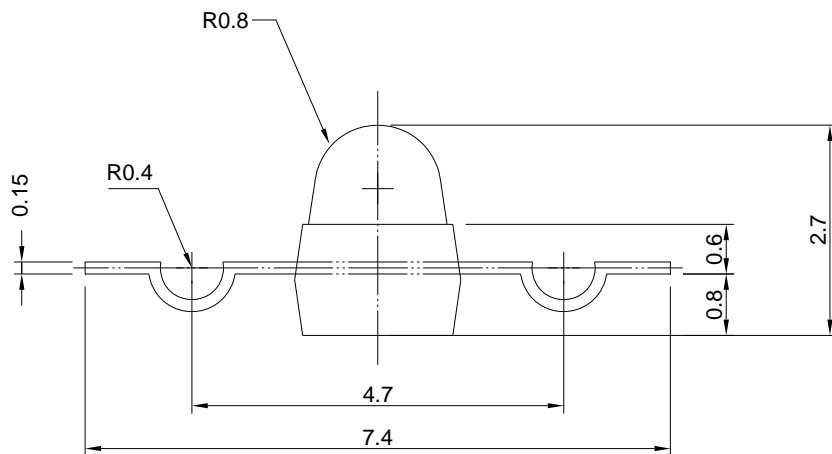
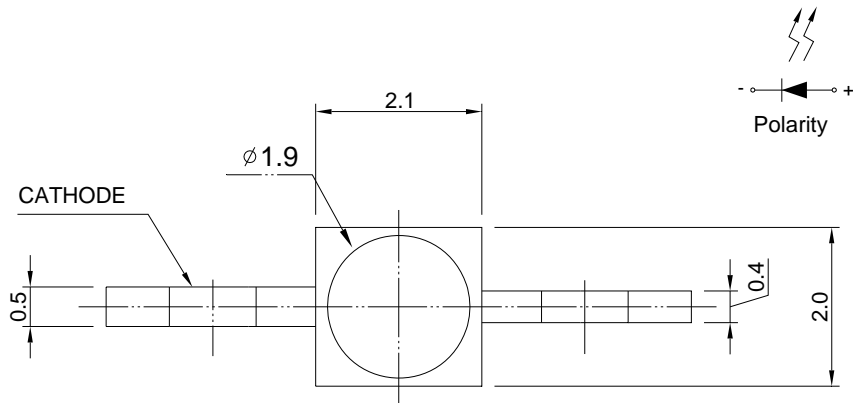

Notes:

1. All dimensions are millimeters.
2. Tolerance is ± 0.2 mm unless otherwise specified.
3. Specifications are subject to change without notice.

Optical Characteristics Curves

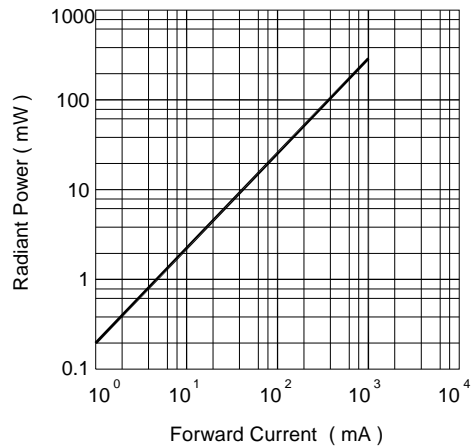
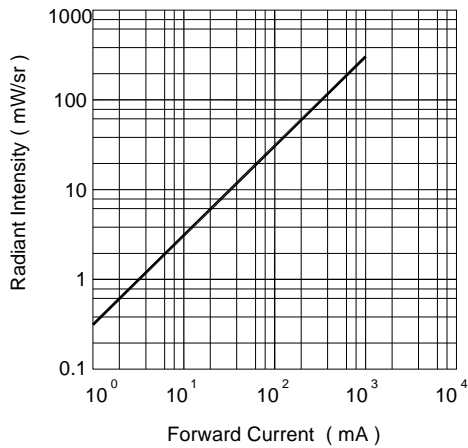
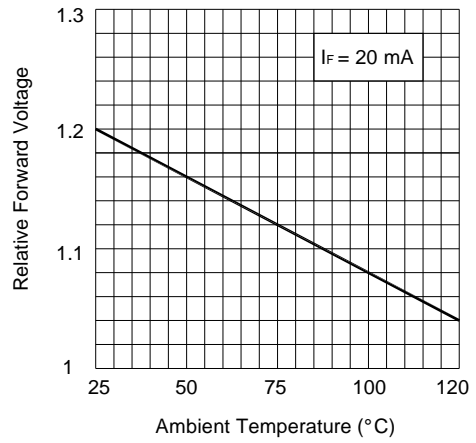
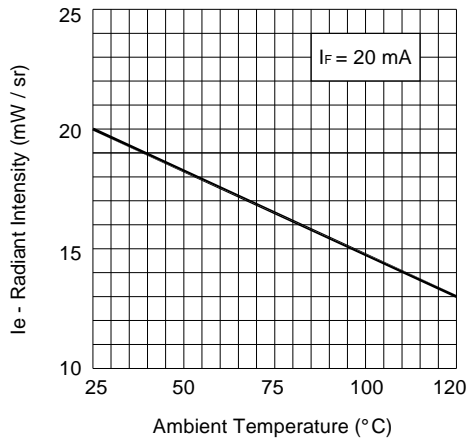
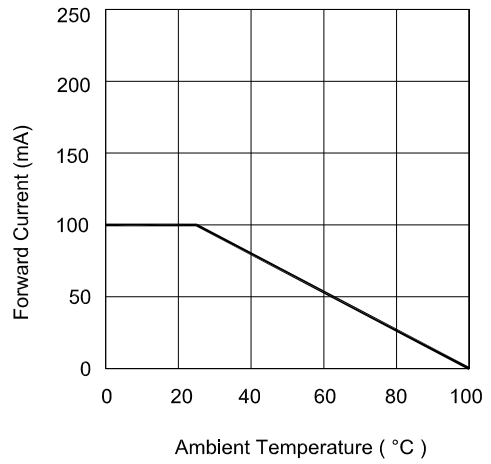
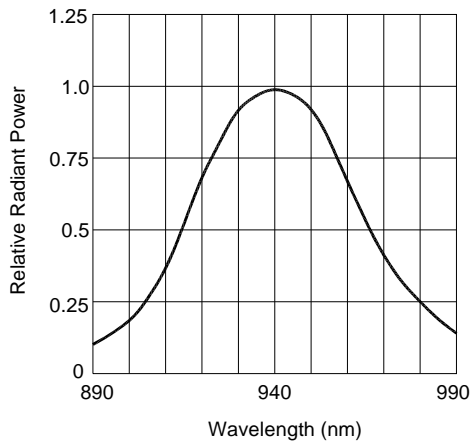

Reel Dimension:

unit : mm

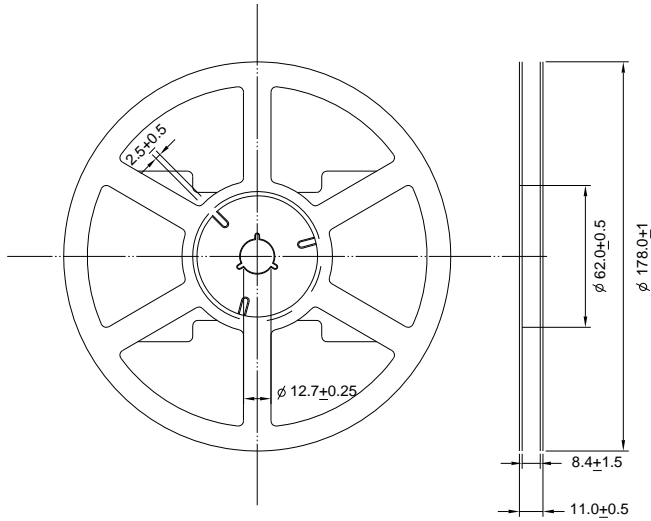

Note:

Available in 8mm carrier tape on 178mm diameter reels. (1000 pieces)

USER FEED DIRECTION

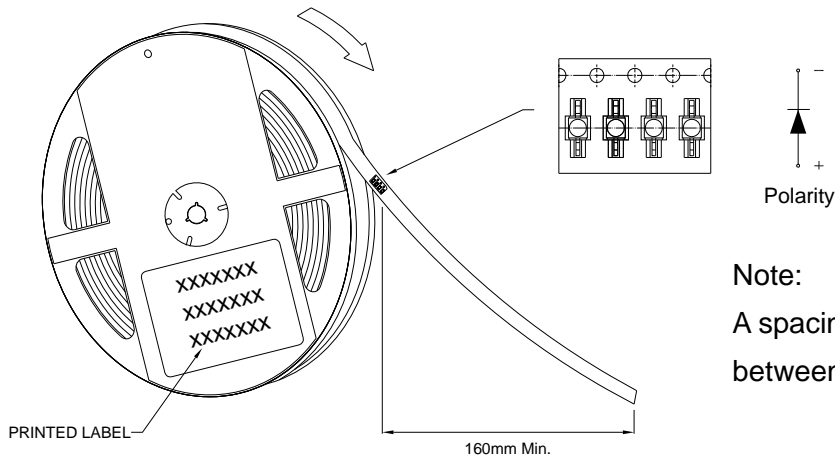

Note:

A spacing of approximately 160mm between the front edge of tape

Tape Dimension:

unit:mm

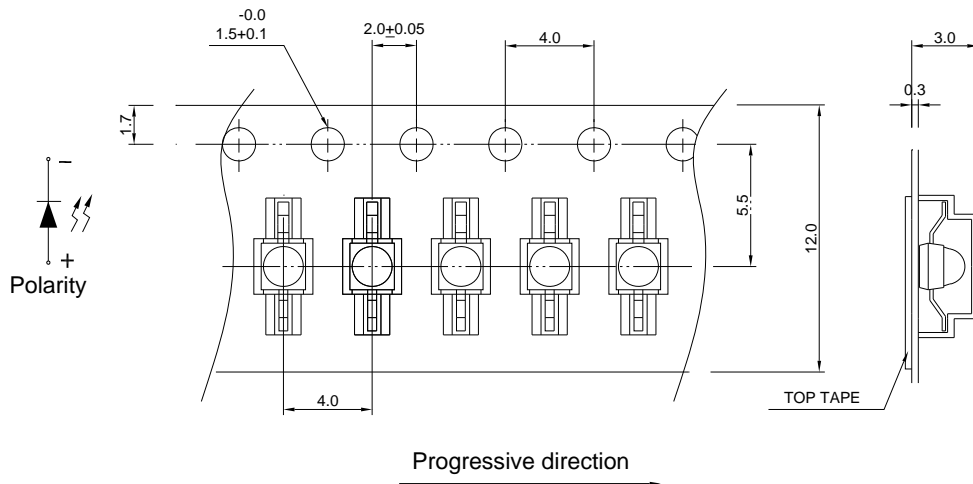

Intensity Specification Rank @ 20 mA

Bin Code	1	2	3	4	5
mW/sr	3.0-4.5	4.0-6.0	5.0-7.5	6.0-9.0	7.0-10.5
Bin Code	6	7	8	9	10
mW/sr	8.0-12.0	9.0-13.5	10.0-15.0	11.0-16.5	12.0-18.0

Recommended re-flow soldering profile:

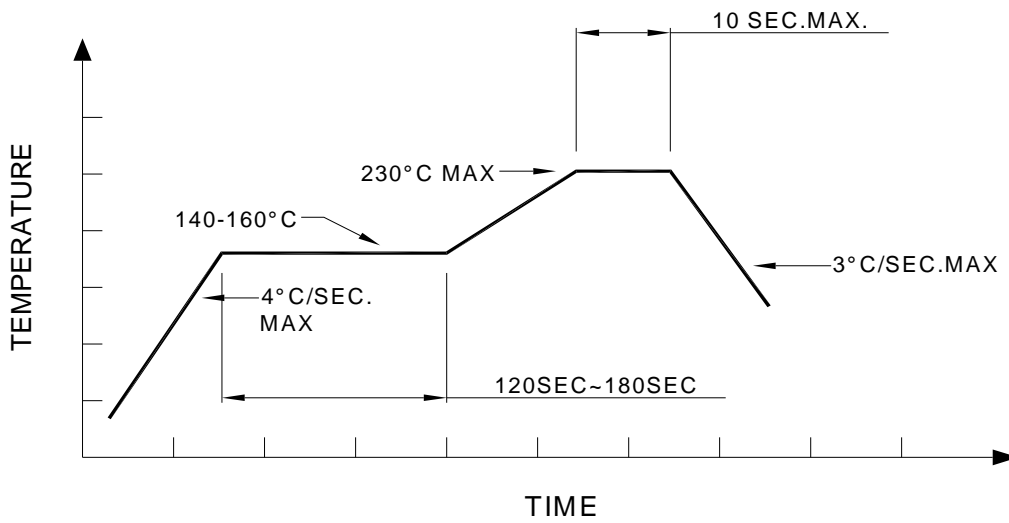

Recommended Pb-free re-flow soldering profile:

